

Male Hex Elbows

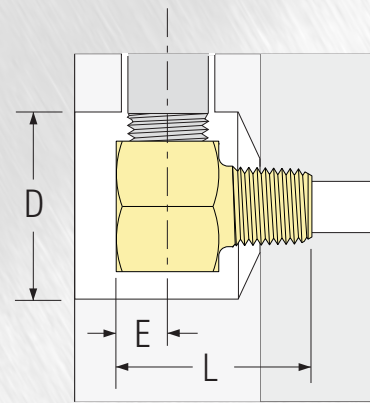
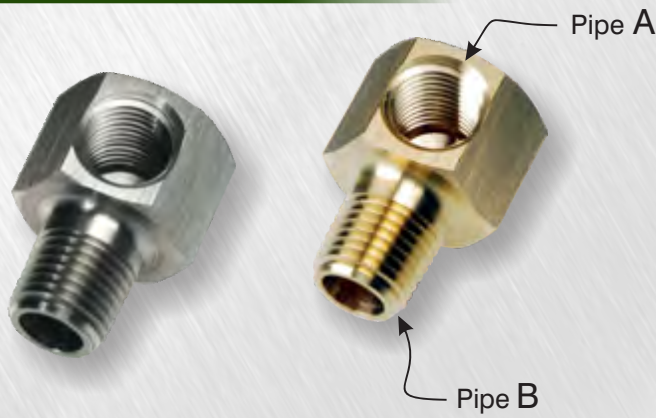

- Available in brass or zinc plated steel.
- Easy socket wrench installation and removal requires minimal clearance.
- Full flow path allows connecting fittings to be torqued tight without choking off flow.

Steel Catalog Number	Brass Catalog Number	Pipe Size A	Pipe Size B	L	E	Wrench Clearance Dia. "D"	Hex Size	Steel	Brass
M16S	M16SB	1/16	1/16	15/16	7/32	1	9/16	•	•
M18S	M18SB	1/8	1/8	1 1/16	9/32	1 1/4	3/4	•	•
M1814S	M1814SB	1/8	1/4	1 1/16	9/32	1 1/4	3/4	•	•
M14S	M14SB	1/4	1/4	1 5/16	11/32	1 3/8	7/8	•	•
M1438S	M1438SB	1/4	3/8	1 5/16	11/32	1 3/8	7/8	•	•
M38S	M38SB	3/8	3/8	1 5/8	7/16	1 1/2	1	•	•
M50S	M50SB	1/2	1/2	2	9/16	1 7/8	1 1/4	•	•
M75S	M75SB	3/4	3/4	2 1/8	5/8	2 1/4	1 1/2	•	•

Brass Extension Elbows

- Positive socket wrench installation.
- One piece construction ensures positive alignment, and complete removal.
- Easy length adjustment with the pre-cut thread system.
- Custom elbows are available in a wide variety of thread combinations. (Including BSPT)

Adjustable threads for use when exact length adjustment is required

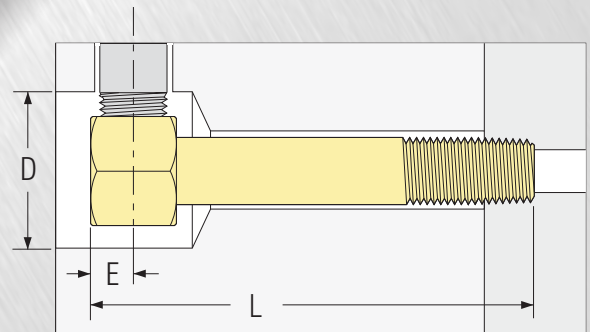
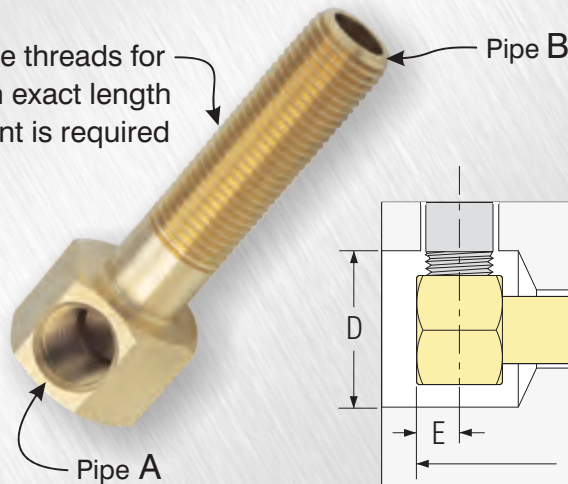

Catalog Number	Pipe Size A	Pipe Size B	Hex Size	Wrench Clearance Dia "D"	E	Overall Length "L"							
						2 1/2"	4"	5 1/2"	7"	8 1/2"	10"	11 1/2"	13"
18B-	1/8	1/8	3/4	1 1/4	9/32	•	•	•	•	•	•	•	•
1814B-	1/8	1/4	3/4	1 1/4	9/32	•	•	•	•	•	•	•	•
14B-	1/4	1/4	7/8	1 3/8	11/32	•	•	•	•	•	•	•	•
1438B-	1/4	3/8	7/8	1 3/8	11/32	•	•	•	•	•	•	•	•
38B-	3/8	3/8	1	1 1/2	1/2	•	•	•	•	•	•	•	•
50B-	1/2	1/2	1 1/4	1 3/4	5/8	•	•	•	•	•	•	•	•

To order, specify Catalog Number and Overall Length
Example: 14B-2 1/2

STK ITEM

Hex Key Street EL's

- HexKey Street Elbows install with an Allen wrench for easy assembly in tight spaces.
- Angular flow path allows connecting fittings to be torqued tight without choking off flow.

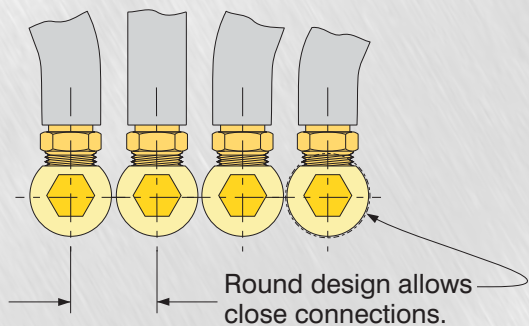
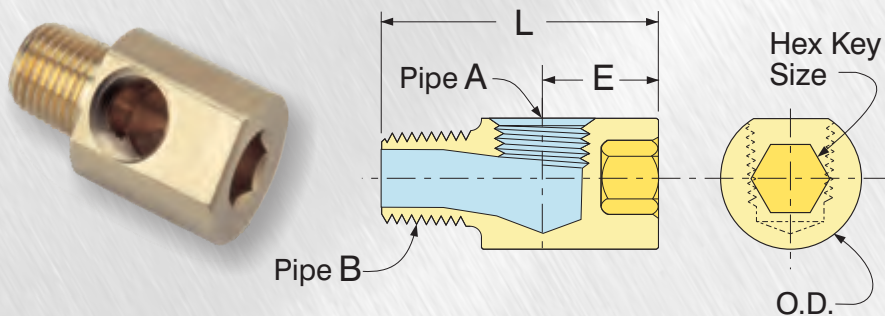

Catalog Number	Pipe Size A	Pipe Size B	L	E	O.D.	Min. Clearance Diameter	Hex Key Size	Stock Item
KL16	1/16	1/16	1.156	.531	.552	9/16	1/4	•
KL1618	1/16	1/8	1.218	.531	.615	5/8	5/16	•
KL18	1/8	1/8	1.312	.580	.615	5/8	5/16	•
KL1814	1/8	1/4	1.500	.593	.860	7/8	3/8	•
KL14	1/4	1/4	1.625	.660	.860	7/8	3/8	•
KL1438	1/4	3/8	1.625	.712	.985	1	1/2	•
KL38	3/8	3/8	1.750	.780	.985	1	1/2	•
KL50	1/2	1/2	2.250	.940	1.235	1 1/4	1/2	•

Hex Key Extension Elbows

HexKey Extension Elbows are round, and install with an Allen wrench. Wrench clearance is not required, making these elbows ideal for use inside the mold, or anywhere space is limited.

- Angular flow path allows connecting pipe fittings to be torqued tight without choking off flow.
- Accurate length adjustments are easy with the patented Custom Mold thread system.

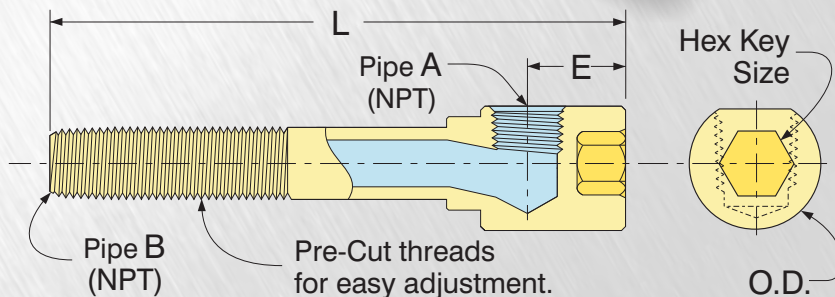
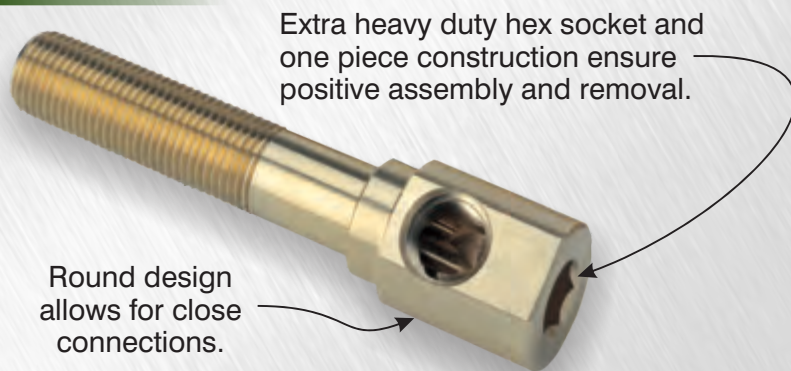

Catalog Number	Pipe Size A	Pipe Size B	E	O.D.	Min. Clearance Diameter	Hex Key Size	Overall Length "L"								STK ITEM		
							2 1/2"	4"	5 1/2"	7"	8 1/2"	10"	11 1/2"	13"			
EKL16-	1/16	1/16	.531	.552	9/16	1/4	•	•	•	•	•	•	•	•	•	•	•
EKL18-	1/8	1/8	.580	.615	5/8	5/16	•	•	•	•	•	•	•	•	•	•	•
EKL14-	1/4	1/4	.660	.860	7/8	3/8	•	•	•	•	•	•	•	•	•	•	•
EKL38-	3/8	3/8	.780	.985	1	1/2	•	•	•	•	•	•	•	•	•	•	•
EKL50-	1/2	1/2	.940	1.235	1 1/4	1/2	•	•	•	•	•	•	•	•	•	•	•

To Order, specify Catalog Number & Overall Length. Example: EKL14-2 1/2

Hex Key Elbows

 **HexKey** elbows install with an Allen wrench for positive assembly and removal.

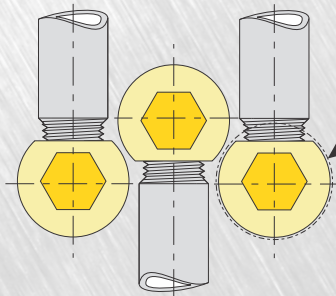
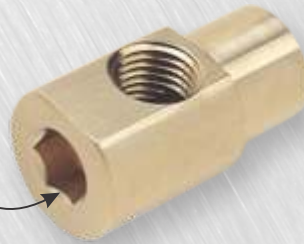

Compact, round design allows for close connections. (See Min. Clearance Dia.)

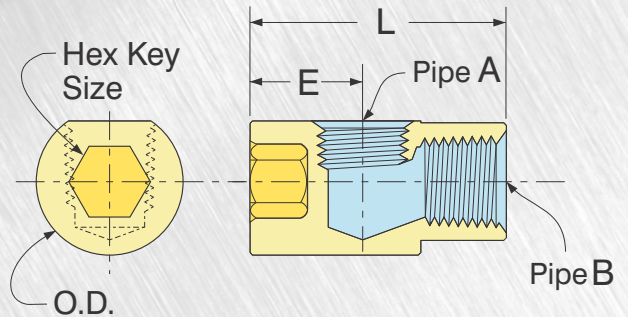

- Angular coolant path prevents fitting interference at assembly and guarantees full flow. (See Drawing)
- Requires smaller swing clearance than standard pipe elbows.
- Order Adjustable Pipe Nipples, or other pipe nipples on pages 24-25.

Catalog Number	Pipe Size A	Pipe Size B	L	E	O.D.	Min. Clearance Diameter	Hex Key Size	Stock Item
HKL16	1/16	1/16	1.125	.531	.552	9/16	1/4	•
HKL18	1/8	1/8	1.250	.580	.615	5/8	5/16	•
HKL1814	1/8	1/4	1.375	.593	.860	7/8	3/8	•
HKL14	1/4	1/4	1.500	.660	.860	7/8	3/8	•
HKL1438	1/4	3/8	1.625	.712	.985	1	1/2	•
HKL38	3/8	3/8	1.750	.780	.985	1	1/2	•
HKL50	1/2	1/2	2.125	.940	1.235	1 1/4	1/2	•

Hex Elbows

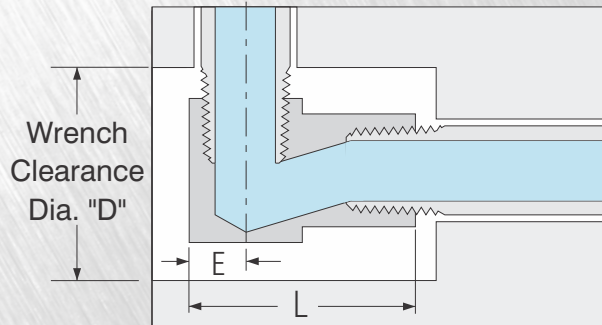
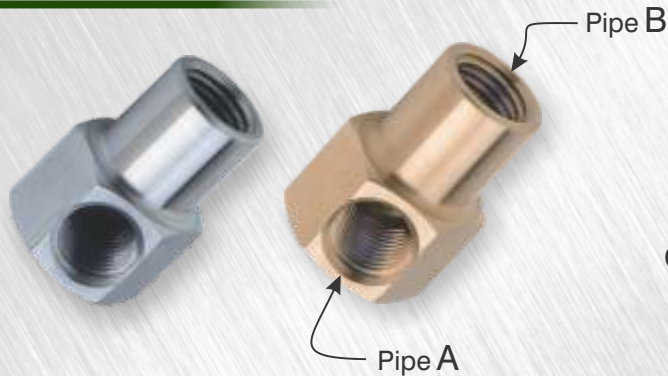

- Available in brass or zinc plated steel.
- Easy socket wrench installation and removal.
- Angular flow path allows connecting fittings to be torqued tight without choking off flow.
- Requires much smaller clearance diameter than standard pipe elbows.
- Order Adjustable Pipe Nipples, or other pipe nipples on pages 24-25.

Steel Catalog Number	Brass Catalog Number	Pipe Size A	Pipe Size B	L	E	Wrench Clearance Dia. "D"	Hex Size	Steel	Brass
16S	16SB	1/16	1/16	13/16	7/32	1	9/16	•	•
18S	18SB	1/8	1/8	1	9/32	1 1/4	3/4	•	•
1814S	1814SB	1/8	1/4	1 1/8	9/32	1 1/4	3/4	•	•
14S	14SB	1/4	1/4	1 1/4	11/32	1 3/8	7/8	•	•
1438S	1438SB	1/4	3/8	1 3/8	11/32	1 3/8	7/8	•	•
38S	38SB	3/8	3/8	1 5/8	1/2	1 1/2	1	•	•
50S	50SB	1/2	1/2	1 7/8	9/16	1 7/8	1 1/4	•	•
75S	75SB	3/4	3/4	2 1/4	5/8	2 1/4	1 1/2	•	•